

# MUSTAD LONGLINE AS

Innovating targeted fishing systems to sustain harvests with SolidWorks software

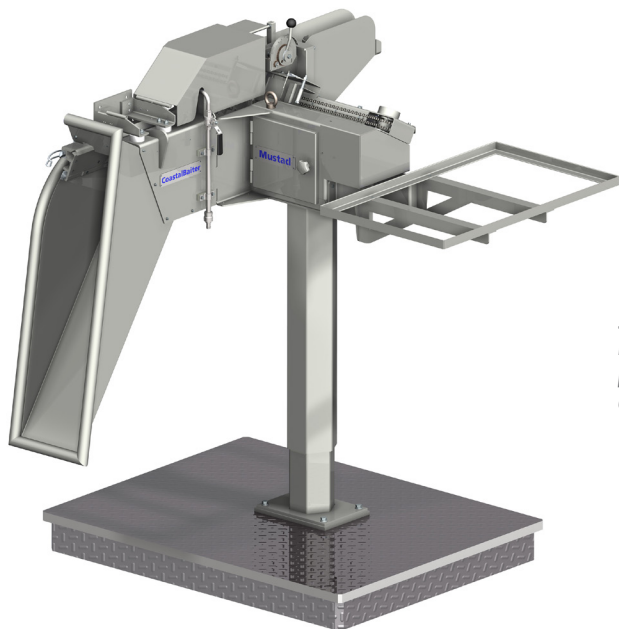

*SolidWorks software has enabled Mustad Longline to increase productivity, improve accuracy, and expand its product line.*

For six generations, the Mustad family has helped the world's fishing fleets harvest the bounty of the seas. Founded in 1832, and Norway's first multinational company, Mustad AS has grown to become a leading manufacturer of fishing tackle, offering more than 15,000 different types of hooks.

In 1972, Mustad launched Mustad Longline AS, a subsidiary that revolutionized the more responsible and sustainable method of longline fishing. Unlike trawling and gill-net fishing, longline fishing targets a specific species and does not damage the seabed or indiscriminately harvest sea creatures. Longline fishing eliminates the environmental waste associated with after-catches, which are estimated to be as high as 30 percent with some netting methods.

As the leader in automated longlining systems—with more than 90 percent of the world's market share—Mustad Longline strives to offer reliable, innovative equipment to its customers. In 2000, management decided to evaluate whether a move from the AutoCAD® 2D design tools that Mustad engineers had used to a 3D CAD system would increase productivity and spur development.

"It was easy to see that we needed to go from 2D to 3D to be able to produce the greater number of new designs that was expected of us," recalls Product Developer Geir Rogne. "At the time, there were two relevant 3D CAD systems on the market, SolidWorks® software and Autodesk Inventor®. After comparing them, we agreed that SolidWorks 3D CAD software was much better developed. Following a thorough evaluation process, we chose SolidWorks software as our company's 3D CAD standard. It was a decision based on an overall judgment and not on any special features."

## Challenge:

Innovate new, sustainable longline fishing systems by increasing productivity and streamlining development.

## Solution:

Standardize on SolidWorks Professional 3D design, SolidWorks Enterprise PDM product data management, and 3DVIA Composer technical communication software.

## Results:

- Increased productivity by 80 percent
- Improved efficiency through design reuse
- Eliminated design errors
- Streamlined service manual production

After implementing SolidWorks Professional for design, the company added SolidWorks Enterprise PDM for product data management and 3DVIA Composer™ for technical communication. "SolidWorks software has allowed us to experience a totally new three-dimensional world. We are very satisfied with how it all works and how much our productivity has increased since acquiring our new design tool."

### Increased productivity supports new product development

The productivity boost that Mustad Longline has realized since moving to SolidWorks software is substantial. Today, four engineers complete the work that would have once required a staff of 20, a productivity jump of 80 percent. Because the company's Design department is more efficient, the company has expanded its product offering—most notably through the development of the Select Fish System™ for smaller vessels of 40 to 90 feet in length.

"It's an amazing difference," Rogne stresses. "And it's not just the speed that has improved with SolidWorks software—the accuracy has also been much better. For instance, we have been able to skip the 0-series on our new systems and move directly from the prototype to manufacturing. That saves a lot of time and cost as well."

### Reducing weight for smaller boats

SolidWorks software is helping Mustad Longline engineers resolve emerging product design challenges. For example, because the Select Fish System is designed for use by smaller boats, weight is a more important consideration in terms of stability than it is on larger ships. The company's engineers had to explore the use of lightweight materials, and leveraged SolidWorks Professional to simulate performance and reduce dimensions.

"Without the simulation tools in SolidWorks software, the design of this product would have been more difficult to do, and definitely more time- and cost-consuming," Rogne notes. "The improvements in accuracy provided by SolidWorks software are also due to the fact that we can now make simulations at an early stage in the process and be confident that nothing will collide or interfere. It's especially useful for big and complicated designs."

### Greater design reuse and better documentation

Mustad Longline realizes additional benefits by using SolidWorks Enterprise PDM to maximize design reuse and maintain revision control, and by leveraging 3DVIA Composer to automate and streamline the production of service manuals. The company decided to replace its former PDM solution, DBWorks, with SolidWorks Enterprise PDM because it wasn't satisfied with the support it received from its supplier.

"Our PDM system also contributes to greater efficiency in the Design department," Rogne points out. "We can easily find existing designs or design components to modify and reuse in new 3D models. The wheel has already been invented, so it doesn't make sense to do that over and over again."

"A year ago, we added a 3DVIA Composer license to our CAD software environment, and that was a great improvement for producing service manuals," Rogne adds. "We needed a single documentation solution to meet all our needs, and that's why we chose 3DVIA Composer, which we also use for making educational materials for use in our training courses."

*"SOLIDWORKS SOFTWARE HAS ALLOWED US TO EXPERIENCE A TOTALLY NEW THREE-DIMENSIONAL WORLD. WE ARE VERY SATISFIED WITH HOW IT ALL WORKS AND HOW MUCH OUR PRODUCTIVITY HAS INCREASED SINCE ACQUIRING OUR NEW DESIGN TOOL."*

Geir Rogne  
Product Developer

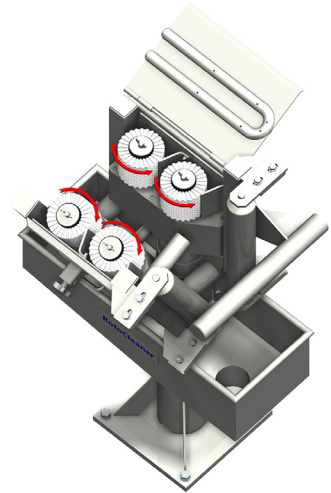
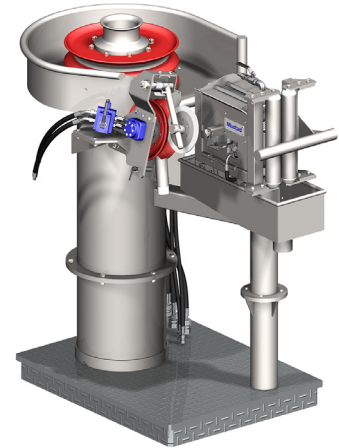

SolidWorks Simulation, SolidWorks Enterprise PDM, and 3DVIA Composer provide Mustad Longline with additional productivity benefits, including fewer errors, greater design reuse, tighter revision control, and automated documentation production.

**Mustad**

- A better way to fish

Mustad Longline AS  
P.O. Box 41  
N-2801 Gjøvik  
NORWAY  
Phone: +47 61 13 77 00  
www.mustad-autoline.com  
VAR: ProNor AS, Jessheim,  
Norway



Dassault Systèmes  
SolidWorks Corp.  
300 Baker Avenue  
Concord, MA 01742 USA  
Phone: 1 800 693 9000  
Outside the US: +1 978 371 5011  
Email: info@solidworks.com  
www.solidworks.com

3dvia  composer

  
**SolidWorks**